

user manual

pco.edge

rolling shutter version



pco.
imaging

In this manual you find instructions for the pco.edge scientific CMOS camera.

Target Audience: This camera is designed for use by technicians, engineers, and scientists.

In case of any questions or comments, please contact us at PCO.



telephone	+49 (0) 9441 2005 50
fax	+49 (0) 9441 2005 20
email	info@pco.de
postal address	PCO AG Donaupark 11 93309 Kelheim, Germany

The cover photo shows an exemplary PCO camera system.
The lens is sold separately.

Copyright © 2011 PCO AG (called PCO in the following text), Kelheim, Germany. All rights reserved. PCO assumes no responsibility for errors or omissions in these materials. These materials are provided "as is" without warranty of any kind, either expressed or implied, including but not limited to, the implied warranties of merchantability, fitness for a particular purpose, or non-infringement. PCO further does not warrant the accuracy or completeness of the information, text, graphics, links or other items contained within these materials. PCO shall not be liable for any special, indirect, incidental, or consequential damages, including without limitation, lost revenues or lost profits, which may result from the use of these materials. The information is subject to change without notice and does not represent a commitment on the part of PCO in the future. PCO hereby authorizes you to copy documents for non-commercial use within your organization only. In consideration of this authorization, you agree that any copy of these documents, which you make, shall retain all copyright and other proprietary notices contained herein. Each individual document published by PCO may contain other proprietary notices and copyright information relating to that individual document. Nothing contained herein shall be construed as conferring by implication or otherwise any license or right under any patent or trademark of PCO or any third party. Except as expressly provided, above nothing contained herein shall be construed as conferring any license or right under any PCO copyright. Note that any product, process, or technology in this document may be the subject of other intellectual property rights reserved by PCO, and may not be licensed hereunder.

Updated January 2011 © PCO AG

Table of Contents

1	Introduction	4
	The new imaging standard.	
2	Safety Instructions	5
	Save money, reduce stress, stay healthy	
3	System Components	6
	What's in the Box?	
4	Installation	7
	Get your camera and computer ready for start.	
5	Quick Start	8
	How to get an image fast and easy	
6	Camera Control for the pco.edge	9
	The main interface for all camera settings	
	6.1 The "Camera Control" window	9
	6.2 The <i>Timing</i> sheet	10
	6.3 The <i>Sensor (Size)</i> sheet	14
	6.4 The <i>Sensor (Misc.)</i> sheet	15
	6.5 The <i>Recording</i> sheet	16
	6.6 The <i>In/Out Signals</i> sheet	18
7	Camware Features	19
	Software for image acquisition and archiving	
	7.1 If no camera is connected	19
	7.2 Overview	20
	7.3 The File Menu.....	21
	7.4 The Camera Menu.....	25
	7.5 The Acquisition Menu.....	26
	7.6 The View Menu.....	27
	7.7 The Window Menu.....	30
	7.8 The Help Menu.....	30
	7.9 The Local Menu.....	31
	7.10 Additional Features.....	32
	Appendix	
A1	Technical Data	34
A2	Mechanical Dimensions	35
A3	How to change optical input F-mount to C-mount	36
A4	Image File Formats	37
A5	Service and Maintenance	39
A6	Customer Service and Trouble Shooting	40
A7	Firmware Update	40
A8	Digital Camera Tools CD-ROM	41
A9	Global Shutter - Rolling Shutter	42
	About PCO	43

1 Introduction

The new imaging standard.



Features

The new pco.edge is a breakthrough in scientific imaging cameras, due to its distinctive ability to simultaneously deliver extremely low noise, fast frame rates, wide dynamic range, high quantum efficiency, high resolution and a large field of view - all in one image.

The camera's main features are:

- low noise: 1.4 electrons
- high resolution: 5.5 megapixel
- high dynamic range: 22000:1
- high speed: 100 fps
- flexibility: user selectable choice of rolling or global shutter
- free of drift: stabilized Peltier cooling in order to avoid any drift phenomena in image sequences

Areas of Application

Live cell microscopy	High content screening
Particle Imaging Velocimetry (PIV)	Photovoltaic inspection
Single molecule detection	X-ray tomography
Super resolution microscopy	Ophthalmology
TIRF microscopy / waveguides	Flow cytometry
Spinning disk confocal microscopy	Biochip reading
Spectral (hyperspectral) imaging	Machine vision
Lucky astronomy / imaging	TV / Broadcasting
Adaptive optics	LIBS
Solar astronomy	FRAP
Genome sequencing (2nd and 3rd gen)	FRET
Fluorescence spectroscopy	
Bio- & Chemi - luminescence	

2 Safety Instructions



Never operate the camera in humid or dusty environments or in places with high amounts of X-ray radiation. **Humidity, dust or X-rays could damage the camera.**



To avoid the risk of water condensation, protect the camera against extreme changes of ambient temperature. **If condensation enters the camera, there is the risk of electric shock.**



To prevent damage to the camera, **the system must be kept stable and protected against strong jolts or vibrations.** The socket at the bottom of the camera is to be used for mounting purposes only.



The slits in the camera case (side & back planes) are designed for heat dissipation by the camera fan. **To prevent overheating of the camera, do not block these slits.** Do not leave the camera system in direct sunlight to avoid the risk of overheating.



Electric shock warning – **Never slide any items through the slits into the camera** because of the risk of electric shock if the voltage parts inside are touched.



Each time the camera is used, **check the power cable for any damage.**



Never position the cable in a way that it could become a **tripping hazard.**



Do not force the lens onto the camera. To protect the lens connector thread from damage, use minimal force when attaching a lens to the camera.

If any of the following conditions apply, immediately switch off the camera, separate it from the power line and contact our customer support:



- ⚠ If the power cable or the power plug seems to be worn or damaged.
- ⚠ If liquids have penetrated the device.
- ⚠ If, after thoroughly reviewing the instruction manual, the device is still not operating properly.
- ⚠ If the camera has been dropped or the casing is damaged.

3 System Components

The standard camera system includes the following parts.

Camera Head

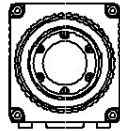

F-mount optical connection (standard)
For standard F-mount/SLR lenses and adapters.

C-mount ring provided (see appendix A3)
For standard C-mount and microscopy connectors.

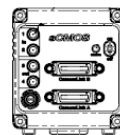

LED indicates camera status

- green continuous: camera is booting
- green blinking: camera is ready for operation
- yellow blinking: recording on
- red blinking: error

Input/Output 4x SMA connectors

2x input - 2x output

Interface

Dual Camera Link 'full'

1/4-20 UNC mounting thread
Serial Number tag

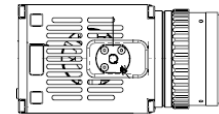

Power Supply

12V AC IEC8 Power Supply with Lemo FGG.0B connector



Power Cord

Standard IEC7 connector (for Germany only)



Camera Link Grabber Card

PCIe x4

Cable

2x Camera Link cables



Digital Camera Tools (CD-ROM)

The accompanying CD contains:

- Camware: software for camera control & image acquisition
- camera & grabber board driver

4 Installation

You will find all necessary files on the accompanying CD.
You may also download the newest versions of our software, camera drivers, and third party software drivers from our website (support section).

Minimum computer system requirements:

- Clock speed > 1.6GHz
 - RAM > 512MB
 - Windows XP/ Service Pack 2
 - 1280 x 1024 pixel resolution display
 - nVIDIA CUDA GPU (see chapter 7.6)
-

4.1 Grabber Installation

Please run the appropriate grabber driver installation with default settings.

For 32bit OS:  RuntimeSetup_v5.1.0a_IA32....
For 64bit OS: (not yet released)

Then shut down computer and install grabber card hardware.

4.2 Camware

The Camware 32-bit Windows application software enables you to control every camera parameter or setting. Images can be displayed on a monitor and may be downloaded and stored.

Please run the respective software installation provided on the CD:

 SW_CAMWAREWIN32_304.exe

After a successful installation, you will find the program file 'Digital Camera Toolbox' in your program directory.

5 Quick Start

Note: In order to get familiar with your new camera & software it might be helpful, if you first aim at an object that is easy to focus and that can be seen at standard light conditions.

5.1 Preparation

- ✓ installation is finished (see chapter 4)
- ✓ an appropriate lens is attached (remove cap!)
or the camera is attached properly to the microscope, spectrograph or other scientific device
- ✓ camera is connected to the power supply
- ✓ camera is connected to the PC

- ✓ computer is on
- ✓ camera is on and ready (green blinking LED)

5.2 Start

- start Camware 



- open view window
- if not already open -



- start "live preview"



- apply "auto range peak"



- you may adjust aperture and focus

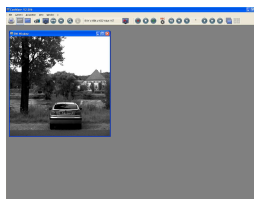

You should now clearly see the object in the window.

- If you need to change exposure time (e.g. the image is still either too dark or too bright), please go to chapter 6!
- If you want to record and save images, please see chapter 6 and chapter 7 for detailed information!

6 Camera Control for the pco.edge

The 'Camera Control' window in Camware is the main interface for all camera settings.

For further Camware features please see chapter 7!

6.1 The "Camera Control" window

The camera control window can be opened by selecting the proper command in the "Camera"-Menu or by the corresponding button in the toolbar:



The camera control dialog always adapts to the camera type connected. For the pco.edge the camera control settings are spread over five **property sheets** ①, which will be explained below.

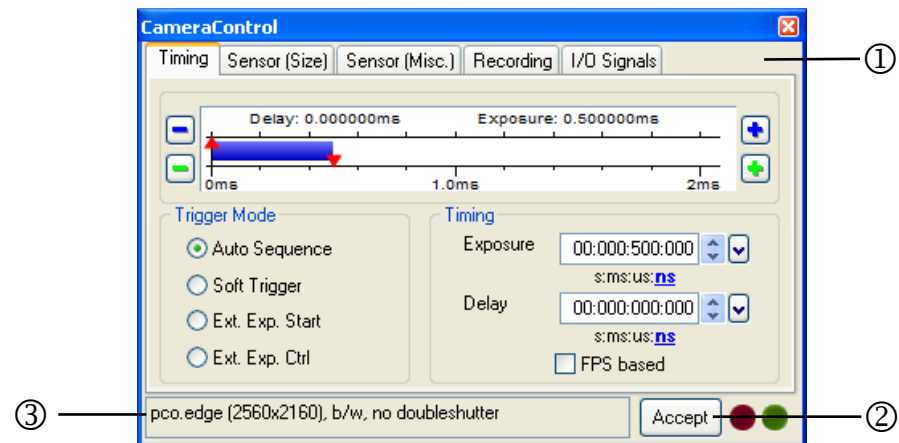

Changes to the camera control sheets must be completed by pressing the **"Accept" button** ②.

If the "Accept" button is not pressed, these changes will be ignored and lost. If the changes are within the allowed condition limits of the camera, a message is sent to the computer, the button disappears and the green lamp will be highlighted. If an illegal change was attempted, the camera will not accept the change and the red lamp will be highlighted.

In the **information field** ③ you can view some information about the camera. Click into the info field in order to scroll through the values.

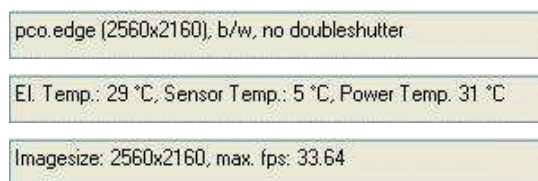

Power Temp.: temperature hotspot close to FPGA

6.2 The “Timing” sheet

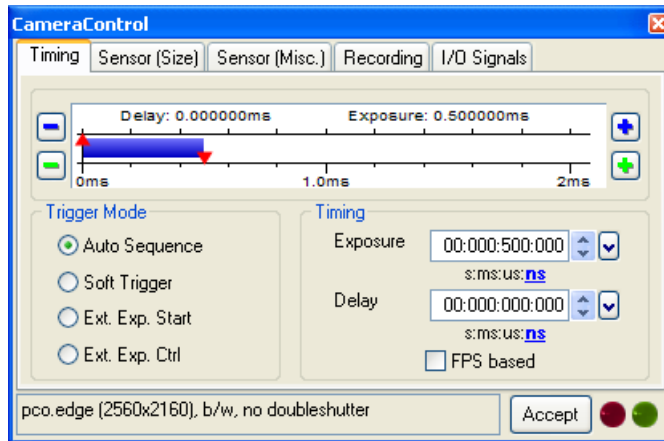

General Information

In this context **trigger** means exposure trigger, i.e. the trigger signal controls the exposure of a single image.

Exposure and readout are done simultaneously, i.e. while image “n” is being readout from the sensor, image “n+1” is already integrated within the sensor’s pixel elements.

In case of short exposure times, the readout is the limiting factor:

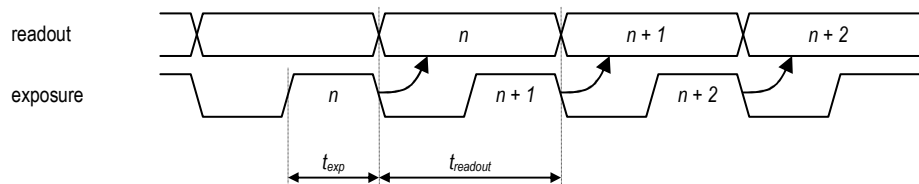

For long exposure times, the exposure time is the limiting factor:

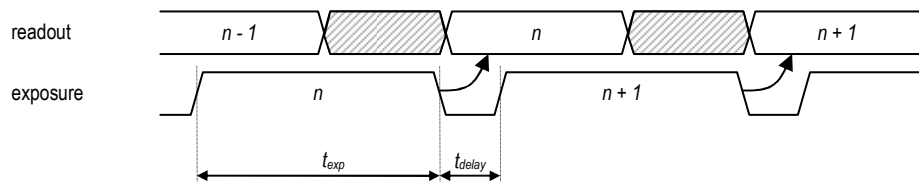

Additional delay time (t_{delay}) will result in reduced frame rate.

Trigger Mode

[Auto Sequence] The camera will optimize the image recording to achieve the best possible frame rate (“free running”).

In the [auto sequence] exposure control mode, the camera determines the fastest possible image uptake rate depending on the adjusted exposure time and the required readout time. After a start command is given, the sequential recording is started until a stop command is given.

[Soft Trigger] Single images can be recorded with Camware control. The single image can be acquired by pressing the "Single Trigger" button. This button appears after pressing the “Start Record” button (see chapter 7.2). Other signals cannot influence this operating mode. For test purposes only.

[External Exp. Start] The image acquisition is triggered by an external signal. It is also possible to force a software trigger for a test image with the "Single Trigger" button.

In the [External Exp. Start] exposure control mode, single image recording is started by the falling or rising edge of the voltage signal at the BNC input (see chapter 6.7). The frame-rate cannot be set, as the frame-rate is defined by the frequency of the external signal. However the exposure time and ROI settings affect the maximum possible frame-rate.

A new trigger is possible after t_{readout} or $(t_{\text{exp}} + t_{\text{sys}})$ (whichever is longer) after the preceding trigger. The Busy Status signal (see chapter 6.7) indicates if a new trigger will be accepted.

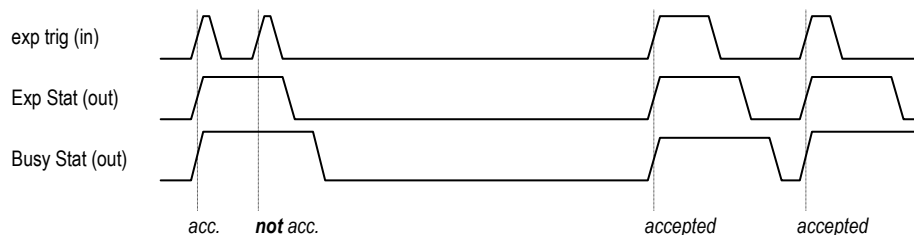

The maximum achievable frame rate in external trigger mode is negligibly less (about 0.1% @ 286MHz) than when operating the camera in [Auto Sequence] mode.

Note: If the trigger rate of the external signal is quite near the maximum possible frame-rate (difference < 1/1000), then it will be random, whether or not a trigger is accepted!

If the trigger rate of the external signal is higher than the maximum possible frame-rate, then every second trigger pulse is ignored. Therefore the actual frame-rate drops to ½ of the external trigger rate. If the trigger rate is increased further, then only every 3rd, every 4th etc. trigger edge will be accepted.

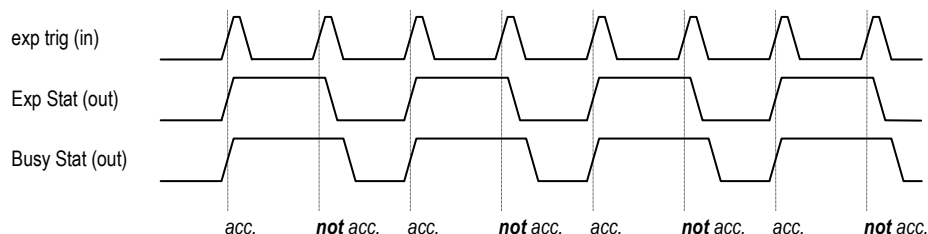

In order to avoid trade-offs at maximum frame-rate use either the Busy Status signal (see chapter 6.7) or make sure that the external trigger rate follows this condition:

$$\text{External Trigger Rate} \leq f_{\text{max}} / 1.001$$

Imagesize: 2560x2160 max. fps: 100.80

6 Camera Control for the pco.edge

[External Exp. Ctrl] An external signal, which is applied to the trigger input, controls the start and the duration of the exposure (see chapter 6.7).

In trigger mode [External Exp. Ctrl] a new exposure is started by the falling or rising edge of the voltage signal at the BNC input (see chapter 6.7). The exposure is finished when the opposite edge is detected. Thus in this mode, the start as well as the length of the exposure time can be controlled.

No further settings can be made, as the image timing is completely controlled by the exp trig signal.

There is a maximum exposure time. If the trigger pulse is longer than 1 s, the integration will be stopped at 1 s.

A new trigger is possible after t_{readout} or $(t_{\text{exp}} + t_{\text{sys}})$ (whichever is longer) after the preceding trigger. The Busy Status signal (see chapter 6.7) indicates if a new trigger will be accepted.



Summary

The detailed timing for external trigger includes system delay times, an adjustable additional delay time, and the jitter.

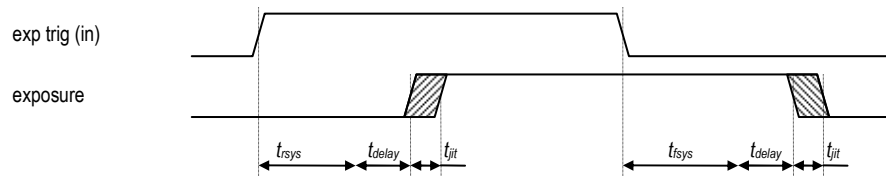

	95.3 MHz	286 MHz
t_{sys}	69 ns	69 ns
t_{jit} (jitter)	0 ... 28 μs	0 ... 10 μs
t_{delay} (delay)	0 ... 2 s	0 ... 2 s

For jitter-free synchronization use the falling edge of the line signal at the status output (see page 18).

There is no specified timing for the software trigger. The software trigger is not recommended for applications where an exact timing is required!

Timing

Please see notes to the external trigger modes for respective timing issues.

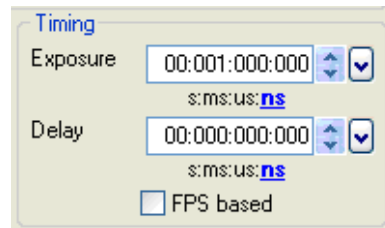

The exposure and delay time can be adjusted in steps of 10µs.

	exposure time	delay time
pco.edge (rolling shutter)	500µs ... 2s	0 µs ... 2s
pco.edge (global shutter)	10µs ... 100ms	0 µs ... 2s

The slider and the up/down control refer to the blue highlighted unit **s:ms:us:ns**.

Additional delay time will reduce frame rate.

[FPS based] The camera will optimize the image recording to achieve the selected frame rate with chosen exposure time as close as possible. Only for [Auto Sequence] trigger mode.

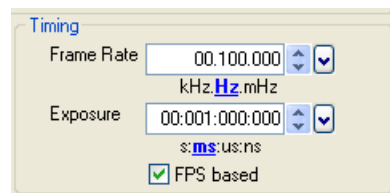

First the frame-rate is set. If the time required for readout of the image is longer than 1 / frame-rate, then the frame-rate will be reduced to 1 / readout.

The frame rate can be adjusted in steps of 100mHz.

If the selected exposure time requires a lower frame-rate, the exposure time is cut to the maximum possible time at that frame-rate.

	Frame rate	exposure time
FPS mode (rolling shutter)	1 ... 33.3 Hz @ 95.3MHz	500µs ... 2s
	1 ... 100 Hz @ 285MHz	

6.3 The “Sensor (Size)” sheet

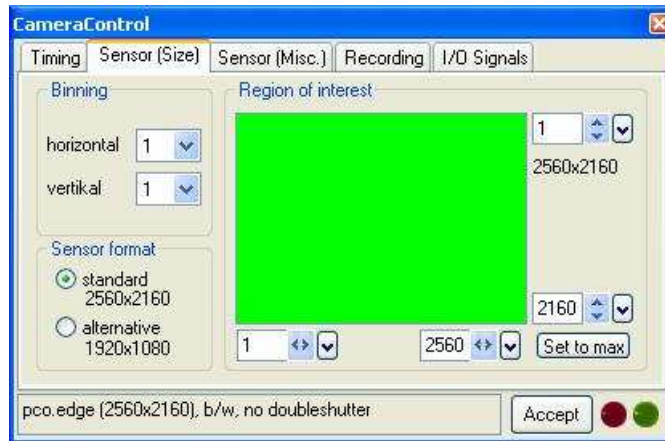

Binning

Feature not applicable for pco.edge

Sensor Format

Here you can choose the preselected HD 'full' (1920 x 1080 pixel) format.

Region of Interest

The ROI (region of interest) selects only a part of the sensor to be read out, in order to speed up the frame rate and to save memory. Due to the sensor structure and readout electronics the selectable region is always symmetric to the horizontal center line.

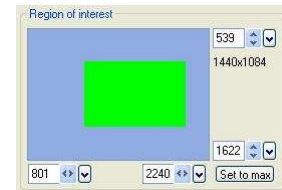

increments horizontal: 160 pixel steps
 increments vertical: 2 pixel steps

minimum ROI: 160 x 16 pixels

Selection of possible ROI with corresponding frame rate values:

resolution horizontal [pixel]	resolution vertical [pixel]	286 MHz		95.3 MHz	
		rolling shutter	global shutter	rolling shutter	global shutter
2560	2160	100	50	33.3	16.7
1920	1080	200	100	66.7	33.3
1600	1200	180	90	60	30
1280	1024	210	105	70	35
640	480	450	225	150	75
320	240	900	450	300	150

Values are for estimation purposes only.

With respect to the minimum exposure time of 500µs (rolling shutter), the maximum frame rate is 2000 fps even at smaller ROIs.

The Camware will show the actual frame rate in the information box:

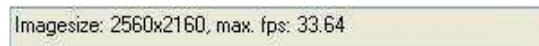

6.4 The “Sensor (Misc.)” sheet

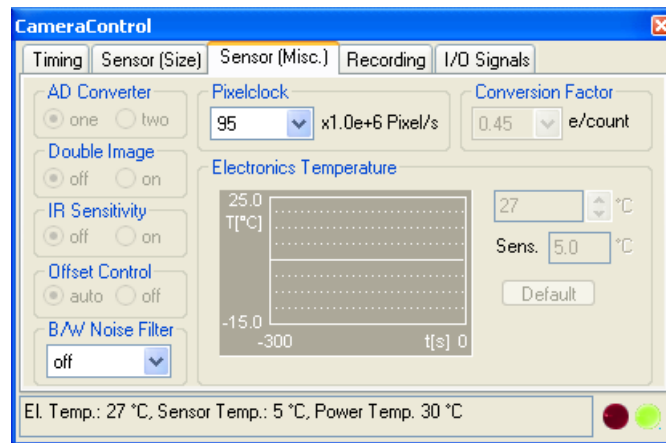

Pixelclock

The pixel clock sets the clock frequency and therefore the image sensor readout speed.

AD Converter

Feature not applicable for pco.edge

Double Image

This feature is widely used for particle image velocimetry (PIV) measurements, but not released for the pco.edge.

IR Sensitivity

Feature not applicable for pco.edge

Offset Control

Offset control is done automatically for optimal results. User control is disabled.

B/W Noise Filter

If you encounter unexpected aliasing effects, turn this filter off.

Conversion Factor

The conversion factor defines how many charges (electrons), which have been generated by light in the image sensor in each pixel, are necessary to generate one count (one intensity level) in the digital image. Therefore, the conversion factor describes the gain that is applied to the signal before it is converted into a digital value. The conversion is optimized for the pco.edge @ 0.47 e⁻/count.

Cooling Setpoint

Display of sensor temperature. Peltier cooling with forced air (fan) is applied in order to keep the sensor's dark current to an acceptable minimum and in order to allow for a continuous operation free of any drift phenomena in image sequences. Regulated to +5°C @ +25°C ambient.

6.5 The “Recording” sheet



Recorder Mode

The Camware will use free RAM space on your computer. The recorded images will be temporarily saved as 16bit multi TIFF. In [Sequence] mode the recording stops when RAM space is full. In [Ring Buffer] mode the camera will stop only by a stop command, hence overwriting previous images. For higher frame rates and longer recording period an appropriate RAID system is necessary. See also the 'Direct Record To File' option on page 24.

Acquire Mode

The acquire mode gives you the ability to enable or disable the recording by an external signal. If set to **[Auto]** all images are accepted and all images taken are saved. A signal at the acq enbl input (see chapter 6.7) is ignored for this function.

If set to **[External]**, the camera will only record images, if the external signal enables recording.

The sensor timing scheme is paused by the signal at the acq enbl input. The acq enbl input is sampled at the beginning of the image generation, which can be seen at the rising edge of the busy stat output. If the acq enbl input is high (low, when inverted) at that time, the image timing starts, it causes an idle state until the acq enbl input is low (high, when inverted).

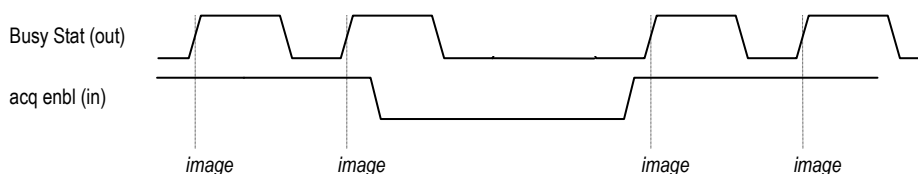

In trigger mode [External Exp. Start], the acq enbl input works like a gate for the trigger signal. A trigger edge (rising, falling when exp trig is inverted) is accepted only when the acq enbl signal is high (low, when inverted).

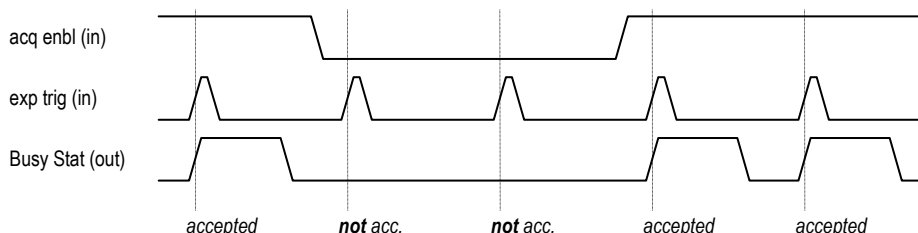

6 Camera Control for the pco.edge

In trigger mode [External Exp. Ctrl], the acq enbl input works very similar to the mode [External Exp. Start]. However, the acq enbl input is ignored for the edge which is closing the exposure time (started exposure will be finished accordingly).

When using acq enbl in external trigger modes, the following timing specification should be met:

$t_{su} = 70 \text{ ns}$
 $t_h = 70 \text{ ns}$

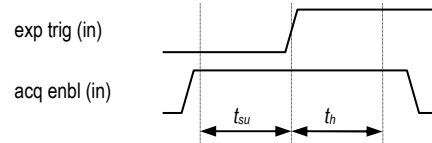

If the acq enbl signal changes within the window of t_{su} (set up) to t_h (hold), the behavior is random. The trigger may be accepted or ignored.

Time Stamp

A time stamp can be placed into the upper left corner of the image. It can be either off, binary, or binary with text or. The time resolution is $1 \mu\text{s}$.

In binary mode the first 16 pixels will be filled with the time stamp information (binary code).

In binary and ASCII mode text will be placed into the image replacing the content of the image (271×8 pixels).



6.6 The “I/O Signals” Sheet

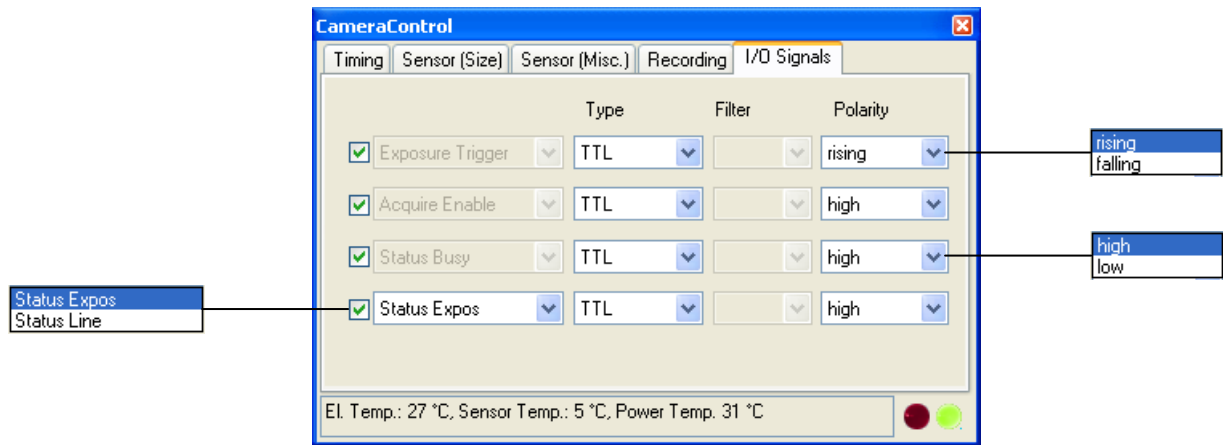

Exposure Trigger

If checked, a signal for [External Exp. Start] or [External Exp. Ctrl] trigger mode (see chapter 6.2) is accepted at the exp trig input.



Status Busy

If checked, a signal indicating busy status is given at the status busy output. Once an acceptable trigger edge is received, busy will go high. As soon as busy goes low again, a new trigger edge is accepted.



Acquire Enable

If checked, a signal for Acquire Mode (see chapter 6.5) is accepted at the acq enbl input.



Status Expos

If checked, a signal indicating exposure status is given at the status output. Status Expos indicates the actual exposure window for one frame.



Status Line

If checked, a signal indicating line status is given at the status output. Use the falling line edge for jitter-free synchronisation (see page 12).



[Type] TTL: Maximum low level: 0.8V
Minimum high level: 2V

[Filter] electrical interference filters

[Polarity] active for high/low signal or rising/falling edge

7 Camware Features

PCO's renowned software for camera control, image acquisition, and archiving of images in various file formats.

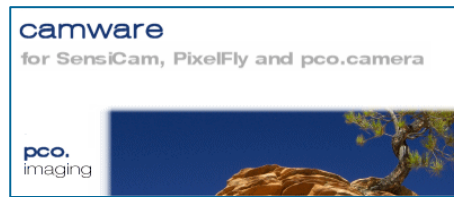

You will find an **online help** under the common Help menu.

Note: There are some features explained in the online help that are not applicable for this camera version.

7.1 If no camera is connected

When Camware is started, it automatically recognizes the camera type of the connected and running cameras.

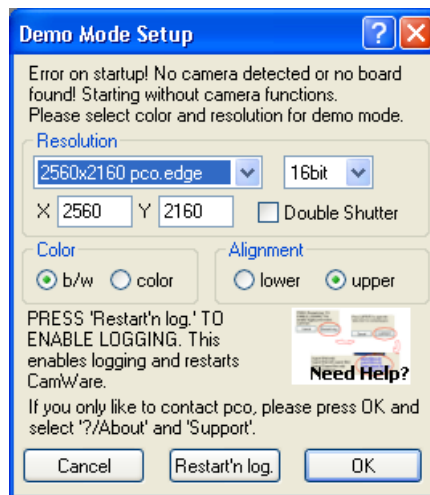

If Camware is started with no camera connected to the PC or with cameras switched off, it starts in demo mode.

In this mode all **image processing** features are available. The user only has to tell Camware which type of images will be opened. For that purpose, the "Demo Mode Setup" window opens and asks for the corresponding input.

Need Help? If this window pops up because you have trouble running the camera, please see instructions in appendix A6.

Resolution

The drop down list offers the existing image sensor spatial resolutions of all PCO camera systems. Please select the specific resolution and bit depth of the images to be opened! If double shutter images have been recorded and should be opened, "Double Shutter Mode" should be checked.

Color

With the radio buttons, the user can specify whether the image type is monochrome or color.

Alignment

These two radio buttons adjust whether MSB aligned ("upper") or LSB aligned ("lower") images have been stored (see page 22, "File Settings").

Settings to view the b16 files of the pco.edge:

	Resolution	bit	DoubleShutter	Color	Alignment
pco.edge	2560x2160	16	<no>	b/w	-
pco.edge color	2560x2160	16	<no>	color	-

7.2 Overview

Menu Bar

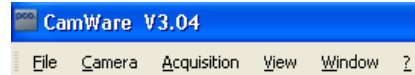

See chapter 7.3 - 7.8.

Local Menu



The "mouse right-click" is explained in chapter 7.9.

Toolbar



	prints the currently displayed image or comment window
	opens a b/w color display window
	opens the camera control window
	opens the convert control
	auto range peak/crop (see chapter 7.6 under "Convert Control BW")
	live preview: useful for fast and easy camera adjustment and focusing This command disables the camera control window if it is opened!
	soft trigger: captures a single image (see chapter 6.2)

Cursor display



Col x:1640 y: 596 R:242 G:255 B:255	cursor: pixel position and intensity value
	continuous "auto range crop" scaling

Recorder



	record START / STOP / PLAY
	opens the recorder settings window
	replay navigation
 	The 'Recorder Browser' gives an overview of the recorded images. A click on the desired image makes it the current image in the Black/White or Color window. 'Skip #images' allows for convenient overview at large numbers of images.
	With the "Multi Frame Window" it is possible to view all active camera images in one window. The user might select between "time" oriented or "camera number" oriented order.

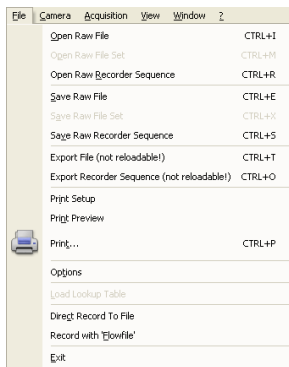

7.3 The File Menu

Open Raw File (single image only)

This command should be used to import a single image into the currently active image window. Only files with the extension and format of "*.b16" (PCO proprietary binary image format) and ".tif" (TIFF image format) can be imported. If the recorder is enabled, each imported image will be transferred to the buffer shown in the picture number. The image itself will be fitted to the current image size. If the recorder is disabled, the current image sizes will be set to the parameters of the imported image.

Open Raw File Set (for hsfc pro camera)

This command is used to open a set of images, previously saved with the 'Save Raw File Set' command. The corresponding windows will be opened automatically. Additionally a comment window will be opened, which shows the settings of the channel and a comment. This option is not accessible in case of the recorder is switched on.

Open Recorder Sequence (image sequence from one camera)

This command is used to import a sequence of images. If more than one camera is connected and an image window is currently open, the sequence will be loaded to the active window. If no image window is open, the images will be loaded to camera #1. This command opens the "Open file" dialog box. Only files with the extension and the format of "*.b16" and ".tif" (TIFF16) can be imported.

Save Raw File (single image only)

The "Save" command should be used to save the image, which is displayed in the active window. The command opens the "Save file" dialog box. The image file can be saved in 16bit "*.b16" and ".tif" format.

If more than one camera is connected, it is possible to save all current images by selecting "Export all images" in the "Save file" dialog box. With this feature it is possible to save one image of each active camera within one process step (it is not necessary to repeat the save process for each camera). The "Save" command will not be available, if there is no image window open. See 6.5 for further information!

Save Raw Set (for hsfc pro camera)

To save one image of each active camera within one single b16 file.

Save Raw Recorder (image sequence from one camera)

The "Save Recorder" command should be used to save or export image records. If more than one camera is connected and an image window is currently open, the record of the active window will be saved. The command opens the "Save file" dialog box. The "Save Recorder" command will not be available, if there is no image window open. See 6.5 for further information!

Export File (not reloadable!)

Use this command to export the image in the active image window. This command will open the Save file dialog box. Files with the extensions ".fts", ".tif", ".bmp", ".asc", ".jpg", and ".jp2" can be exported. This item will be not visible, if there is no image window open.

Note: be aware of the different storage abilities of the formats, for example "*.bmp" - the bitmap format only allows for 8bit values to be stored and therefore the image content of a 12/14/16 bit image is reduced, if stored as bitmap.

Export Recorder Sequence (not reloadable!)

Use this command to export a sequence of images. If more than one channel is connected and an image window is currently open the record of the window which has got the input focus will be saved. If no image window is open the images of channel 1 will be saved. This command will open the Export image dialog box. Files with the extensions "fts", "tif", "bmp", "asc", "avi", "mpg", "jpg", "jp2", and "wmv" can be exported.

If you export recorder files you will not be able to reload them into CamWare!

Print Setup

The "Print Setup" command opens the Windows "Print Setup" dialog box for adjustments and settings of the connected printer(s).

Print Preview

The "Print Preview" command opens a "Print Preview" window.

Print

Opens the Windows "Print" dialog box for the currently displayed image or comment display.

Options

This command opens the "Options" dialog, allowing special settings.

Options: File Settings



Tiff Bit Alignment

Here you can select the alignment of the pixel value, if the pixel depth is less than 16bit (e.g. MSB: each pixel value is shifted from bit 12-1 to bit 16-5 in case of 12bit). This removes the 'dark image effect' inside other image applications.

Tiff RAW

Here you can select whether the 16bit RGB tif file is saved with 16bit raw or white balanced data. If this item is checked, each 16bit RGB pixel value is saved as raw 16bit RGB (48bit) value, without white balancing. Saving to 16bit RGB can be done by selecting the color display window, export recorder, selecting 8bit-tif (!) and checking 'Save 16bit RGB'.

ASCII file separator

Here you can select an appropriate separator for the ASCII file format.

Jpeg High Quality

Here you can select the quality of the saved jpeg/jp2 files. High quality saves images with 100% quality (otherwise 85% quality).

Preserve Last Record

If checked, a message box will pop up in case the user may overwrite or loose data.

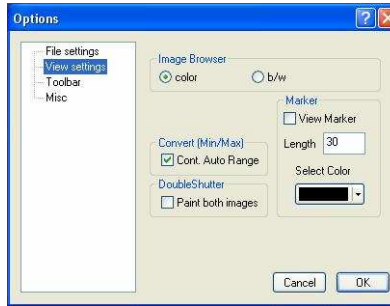
Options: View Settings**Image Browser**

Here you can select between showing all image tiles inside the browser window either b/w or color. Setting b/w will result in a faster refresh. (valid only for color CCD).

Marker

Use this command to display a cross in the centre or elsewhere in the image (see "Set Crosshair" page 31).

Convert (Min/Max) ("Continuous Auto Range Crop", see chapter 7.6 under "Convert Control BW")

This option enables the automatic min/max function during record and replay. Disable this feature if the application stops responding during this mode (due to operating system capacity problems).

Double Shutter:



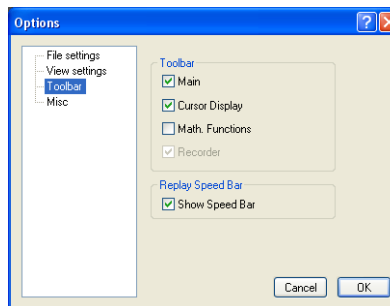

This option enables the update of both double shutter images during record and replay. Disable this feature if the application stops responding during this mode (due to operating system capacity problems).

Options: Toolbar**Toolbar**

Opens the corresponding toolbars (see 7.2)

Math. Functions

With the math window you have the ability to build the difference between a reference image and the actual image. If you activate math every new image acquired will be subtracted from the reference image or vice versa.

-  last acquired image will be copied to reference buffer
-  a reference picture will be acquired and copied to reference buffer
-  add offset here to avoid negative values, which would not be visible
-  enable / disable math function

Replay Speed Bar

The faster replay speed is useful if large sets of image data need to be scanned.

Options: Misc

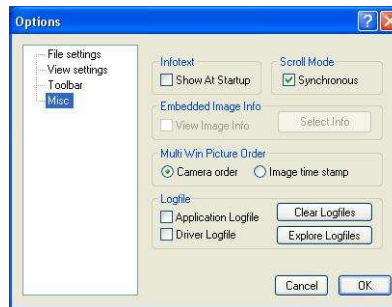

Infotext

Use this command to show or hide the start-up information dialog box.

Synchronous Scrolling

If this item is checked all opened image windows will be scrolled at the same time and in the same manner.

View Embedded Image Info (for pixelfly and sensicam models)

If this item is checked an embedded text will be shown inside the image. See chapter 7.6.

Multi Win Picture Order

With the 'Multi Window' you have the ability to view the images of all active cameras in one window. You can select between 'time' oriented or 'camera number' oriented order. 'Time' oriented means that the sequence of images depends on the individual time stamp of each image. 'Camera number' oriented means that the first image shown is from camera 1, then camera 2 and so on.

Logfile

This option enables the logging of errors and system info. Enable this feature in order to create a support file, which can help to find out troubles with the cameras (see A6 "Customer Service and Trouble Shooting").

Load lookup Table (for monochrome cameras)

With the Pseudo LUT feature you can load any LUT with one of four different formats and you can view the result in the color view window.

Use one of the attached predefined LUTs or define your own.

Direct Record To File

With this command you can preset a certain number of images to be stored directly onto hard disk. If the camera captures images faster than the computer can save to disk, then you will loose images. The displaying of the images doesn't interfere with the record process. See also 'Recorder Mode' on page 16.

Record with 'Flowfile' (for pixelfly and sensicam models)

Exit

This command exits the program and closes all channel dialog windows.

Window positions, settings and sizes are stored in the windows registry and will be loaded again at next start-up.

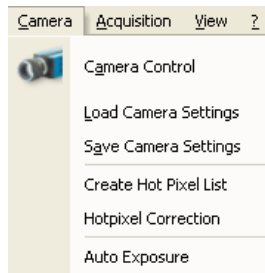

7.4 The Camera Menu

Camera Control

Use this command to open the camera control window (see 6.1).

Load Camera Settings

With this command you can reload camera settings which have been previously saved. You can reload only a file which has been made with the same camera configuration as it was found by the application at start-up.

Save Camera Settings

This command saves the actual camera settings of all existing cameras.

Create Hot Pixel List (for long exposure only)

This feature applies for cameras with exposure times longer than 5s and is not applicable for the pco.edge camera.

Hotpixel Correction (for long exposure only)

Sophisticated hot pixel correction is already implemented in the pco.edge camera.

Auto Exposure

Starts some exposures and tries to find an exposure time that captures images with grey values between 1400 and 1500. It re-adjusts the lookup tables in order to display the images with the new settings best. For low light conditions only.



7.5 The Acquisition Menu

Live Preview

The 'Live Preview' is useful for fast and easy adjusting and focusing of the camera. The active window will be updated. To see another window, simply click on the window. This option is not available in double shutter mode.

Acquire Picture

Records single images in case of pixelfly and sensicam cameras.

Acquire Sequence

Starts recording images into the system memory according to Trigger Mode selection (see 6.2). During the recording, the camera controls are locked.

Rec. Memory Settings

Predefine the number of images in the allocated RAM segment here.



Recorder Settings

This command opens the Recorder Settings dialog window.

The **Play Settings** are referred to the camera. If more than one camera is connected, the camera number is retrieved from the image window that has received the input focus (is active). If no image window is opened, the dialog is referred to camera 1. If the 'Set to all' checkbox is checked the settings apply to all connected cameras.

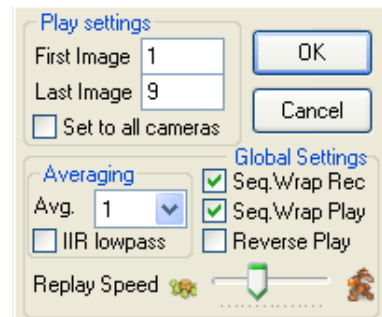

The **Global Settings** are valid for all connected cameras.

Averaging

If in the "Avg." dropdown list a value not equal to 1 is selected, the corresponding number of images is averaged in the buffer, reducing the statistically independent noise.

Another option to reduce the noise is the activation of the "IIR lowpass" IIR-filter: $\text{Image}(\text{act}) = \text{Image}(\text{act} - 1) * 0.5 + \text{Image}(\text{new}) * 0.5$

Replay Speed Slider

The slider can be used to adjust the sequence replay speed, from slow (turtle) to fast (rabbit).

Seq. Wrap Rec

Sequential Wrap Recording sets Recorder Mode (6.6) to "Ring Buffer".

Seq. Wrap Play

The play button starts the display for a sequence as defined by the first image/last image fields and will loop until the stop button is pressed.

Reverse Play

If the "Reverse Play" box is checked, it is possible to play the recorded images in reverse.



7.6 The View Menu

B/W Window

Use this command to open a b/w display window.

Color Window

Use this command to open a color display window.

Convert Control BW

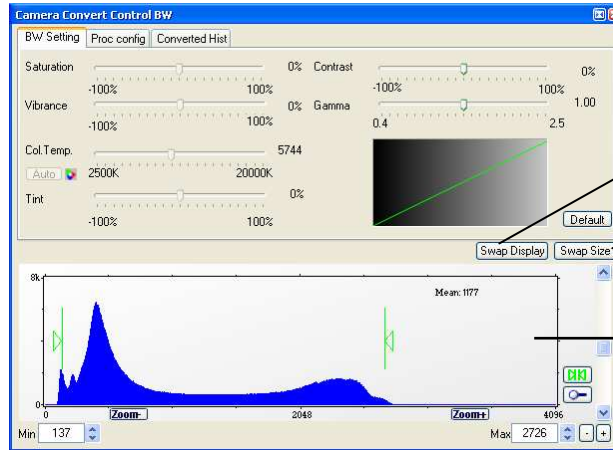

The user can influence how the 16 (12) bit intensity values (x-axis) of the original image are converted into 8 bit values (y-axis) in different ways.

Green sliders in histogram

- left slider = 'Min' controller (corresponds to value "0" of the 8 bit display)
Values below that mark are set to "0", i.e. displayed as black.
- right slider = 'Max' controller (corresponds to value "255")
Values above that mark are set to "255", i.e. displayed as white.

The values in-between are converted into a value between "0" and "255" according to Contrast and Gamma settings. See the small graph, which reflects the calculation.

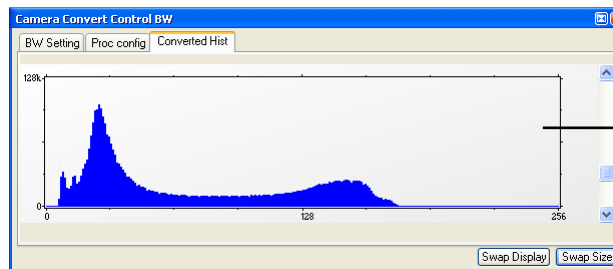

How the Auto Range applies:



Auto Range Peak searches for the minimum and maximum 16 (12) bit intensity values of the image. Given these number the converter scales the 8 bit display (256) within these two values.



Auto Range Crop sets the converter to ignore the extreme intensity values of the image and scales the display in a smaller range. Thus dark or bright light spots, reflections, etc. are cut off.



Min/Max (Automatic) = Continuous Auto Range Crop

'Proc config' sheet: please see under 'Convert Control Color'

Convert Control Color

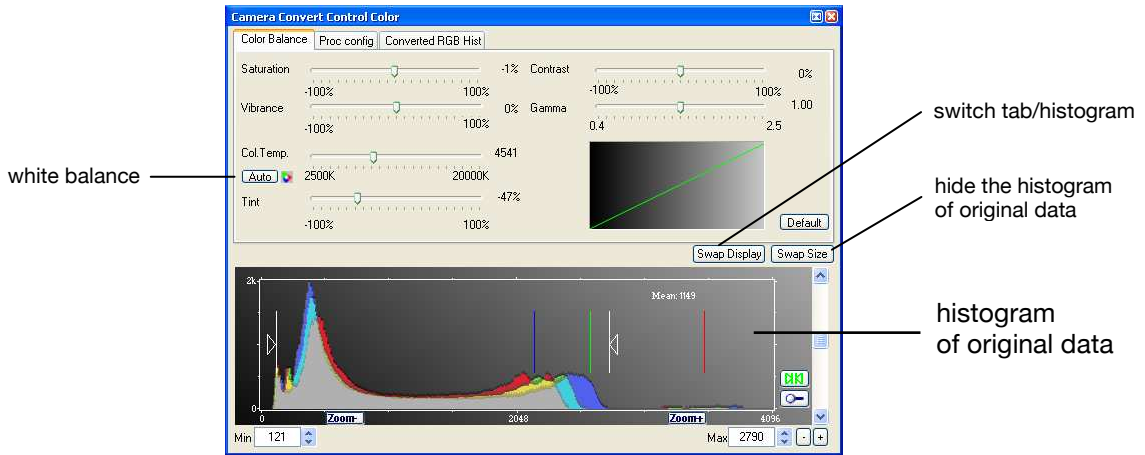

The user can influence how the 16 (12) bit intensity values (x-axis) of the original image are converted into 8 bit values (y-axis) in different ways.

White sliders in histogram

- left slider = 'Min' controller (corresponds to value "0" of the 8 bit display)
Values below that mark are set to "0", i.e. displayed as 'no color'.
- right slider = 'Max' controller (corresponds to value "255")
Values above that mark are set to "255", i.e. displayed as 'full color'.

The values in-between are converted into a value between "0" and "255" according to Contrast and Gamma settings. See the small graph, which reflects the calculation.

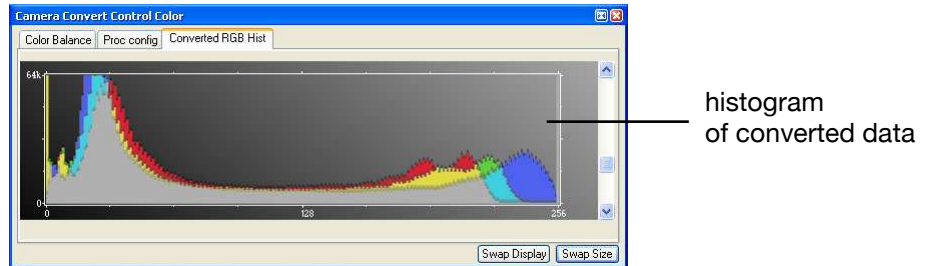

The balancing of RGB can be controlled by Col.Temp and Tint. Press the Auto button to set the white balance.

Intensity of single color can be controlled by Saturation and Vibrance.

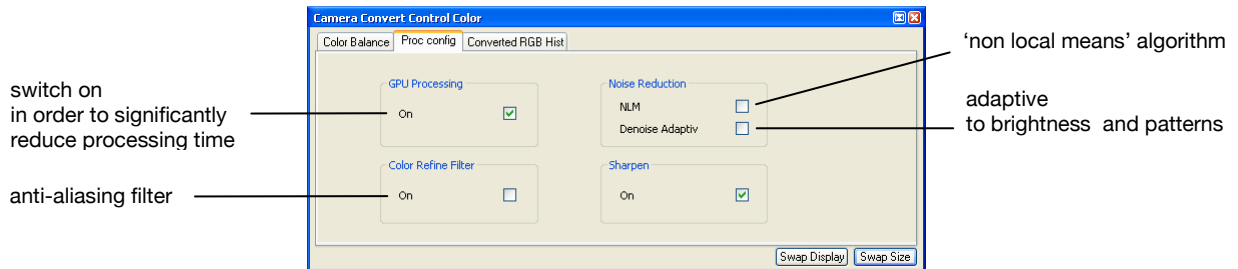

Due to proprietary high-end algorithms used for these image processing features, no detailed description is given here.

Try it and see how the fine details will improve!

GPU Processing

In order to benefit from all of Camware's advanced processing features, we highly recommend a NVIDIA CUDA-enabled graphics processing unit (GPU), e.g. NVIDIA GeForce 9600 GT or better.

Find a list of CUDA-enabled products here:

http://www.nvidia.com/object/cuda_learn_products.html

Get the CUDA driver here:

http://www.nvidia.com/object/cuda_get.html

Make sure:

- that the CUDA driver is successfully installed.
- that the GPU has at least 512MB memory.

AMD's ATI graphics processing units are not yet enabled, but will follow soon.

Camware Image Processing

	color	monochrome
Pre Processing		
Noise Reduction	✓	✓
Bayer Processing		
Bayer Demosaicing	✓	
Sharpen	✓	
Refine Process	✓	
Chroma Blurr	✓	
Post Processing		
Offset, Gain (Min/Max)	✓	✓
Color Correction	✓	
Saturation, Vibrance	✓	
Color Temperature, Tint, White Balance	✓	
Gamma, Contrast	✓	✓

Browser

The 'Recorder Browser' gives an overview of the images in the Recorder, and helps you in an easy way to select a new current image. Simply click on the desired image to make it the current image. It may then be viewed in the Black/White and Color Window.

The Browser window can show up to 40 pictures per page, thus enabling easy printing of the Browser window. You can switch between the single pages by double clicking inside the Browser window or with the local menu (right mouse button).

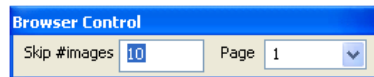

'Skip #images' allows for convenient overview at large numbers of images.

Multi Window

View the images of all active cameras in consecutive order in one window. 'Time' oriented means that the sequence of images depends on the individual time stamp of each image. 'Camera number' oriented means that the first image shown is from camera 1, then camera 2 and so on.

Embedded Image Info (only for pixelfly and sensicam models)

see Timestamp feature in chapter 6.6

7 Camware Features

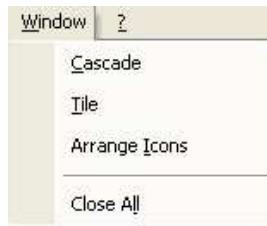

7.7 The Window Menu

Cascade

Show all windows overlapped.

Tile

Tile windows vertically or horizontally.

Arrange Icons

Rearranges all minimized topic icons on the desktop.

Close All

Close all windows.

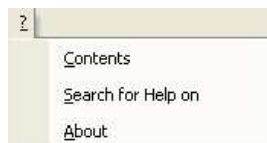

7.8 The Help Menu

Contents

Opens the main page of the online program help.

Search for Help on

Opens an index list for help.

About

This window shows program information and contains helpful support links. In case of a camera problem, support files (see 7.3 Options/Misc/Logfile) may be generated, which can be automatically attached to the email. The support files contain relevant hardware information, the log files and the PCO related registry entries. These files are moved into a zip-archive called "CWSupport.zip", which can be found in the application folder.



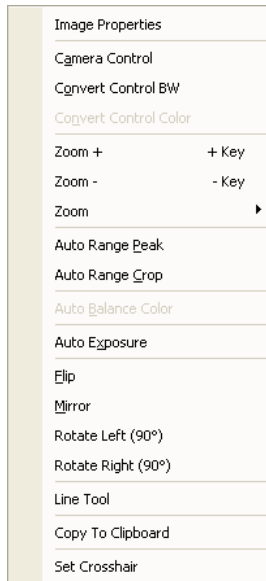

7.9 The Local Menu



The local menu is opened by clicking the right mouse button inside the client area of an image window.

Image Properties

Opens an information bubble with main image properties.



Camera Control

Opens the Camera Control window (see chapter 6).

Convert Control BW/Color

Opens the corresponding Convert Control windows (see 7.6).

Zoom

Changes the zoom used to display the image.

Auto Range Peak/Crop

Displays the image in a predefined scaling (see 7.6).

Auto Balance Color

The white balance feature, which corresponds to the white balance button in the 'Convert Control Color' (see 7.6).

Auto Exposure

Auto Exposure feature (see 7.4)

Flip

The image will be flipped before display.

Mirror

The selected the image will be mirrored before display.

Rotate

The image will be rotated by 90° clockwise (right) or counterclockwise (left) before it is shown in the image window.

Line Tool

Select 'Line Tool' to show a graph, which shows the intensity of the pixels under the red line shown in the image window. The selection of this menu item determines the location of the first point. After this you can move the mouse to the second point, which can be selected by a 'left click'. Now a 'Line Diagram' opens and the length of the line (unit: pixel) is shown in a bubble and displayed in the window.

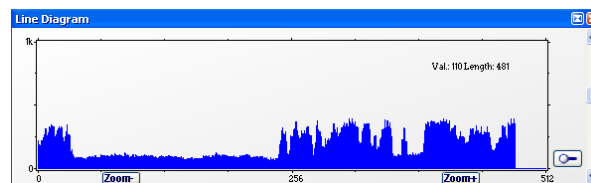

Copy To Clipboard

Copies the active image to clipboard.

Set Crosshair

Move the marker (see page 23) to any point in the image.

7.10 Additional Features

Setting Contrast Area by Mouse

You can control the minimum and maximum values used for the conversion from 16 bit to 8 bit with the mouse. Move the mouse cursor into a region which should be shown with maximum contrast. Press the shift and the left mouse button. Hold down the mouse button while increasing the size of the rubber band window with mouse moves. After releasing of the mouse button the coordinates of the rubber band window act as a border for calculating the minimum and maximum values.

Setting a new ROI by Mouse

In the same manner you can setup a new region of interest (see ROI in Camera control) for the camera. You only have to press the CTRL (Strg) button instead of the shift button. The coordinates of the rubber band window are used for calculating a new region of interest, which will be adapted to the camera capabilities automatically. You can reset the ROI to maximum by pressing the CTRL (Strg) button and the right mouse button.

White Balance by Mouse

In the same manner you can change the 'white balance'. You only have to press the CTRL (Strg) and the shift button at the same time. The pixel values within the coordinates of the rubber band window are used for calculating a new 'white balance'.

For best results we recommend to use the white balance button in the 'Convert Control Color' (see 7.6) or the 'Auto Balance Color' in the Local Menu (see 7.9) respectively.

Fold Up Window

The Convert Control windows can be minimized/folded up. Just move the pointer over the bar and the window will unfold again.

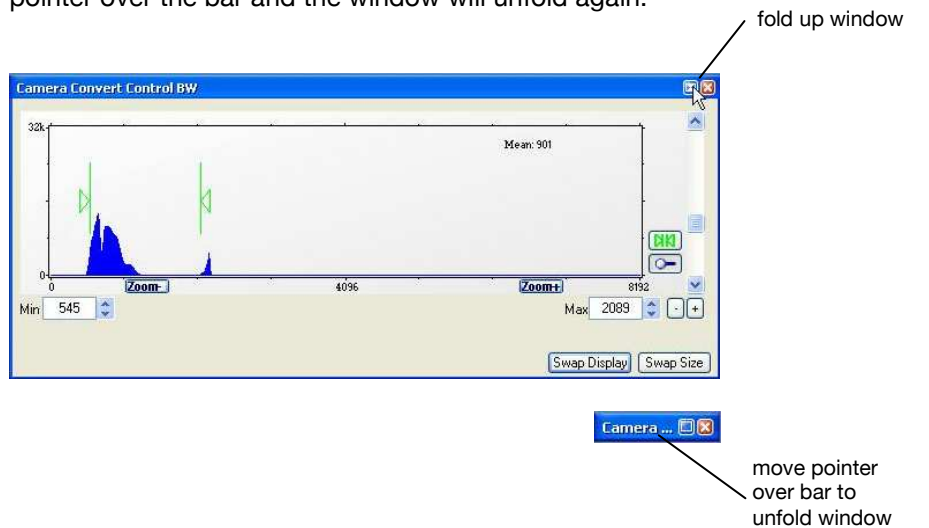

Appendix

A1 Technical Data

	unit	setpoint	pco.edge
resolution (hor x ver)	pixel		2560x2160
pixel size (hor x ver)	μm^2		6.5 x 6.5
sensor format	mm^2		16.6 x 14
sensor diagonal	mm		21.8
quantum efficiency	%	peak	57
full well capacity	e^-		30 000
dark current	$e^-/\text{pixel} \cdot \text{s}$	rolling shutter	2
image sensor			CIS2051
dynamic range	dB		86.9
dynamic range A/D	bit		16
read out noise	e^-_{rms}	@ 286 MHz rolling shutter	< 2.0
imaging frequency (frame rate)	fps	@ full frame @ HD (1920x1080)	100 200
pixel scan rate	MHz		95.3 / 286
pixel data rate	Mpixel/s	@ 286 MHz	572
A/D conversion factor	e^-/count		0.46
spectral range	nm		370 ... 1100
exposure time	ms	rolling shutter	0.5 ... 100
anti-blooming factor			no blooming
smear	%		no smear
optical input			F-/C-mount
trigger, auxiliary signals		internal / external	software / TTL
binning (hor x ver)			-
power supply	VDC		12 ... 24
power consumption	W	max.	20
mechanical dimensions (w x h x l)	mm^3	C-mount	70 x 80 x 102
weight	g		700
ambient temperature	$^{\circ}\text{C}$	range	+10 ... +40
operating humidity	%	range	10 ... 80
storage temperature	$^{\circ}\text{C}$	range	-10 ... +60
data interface			Camera Link
CE / FCC certified			yes

Subject to change, please refer to current data sheet.

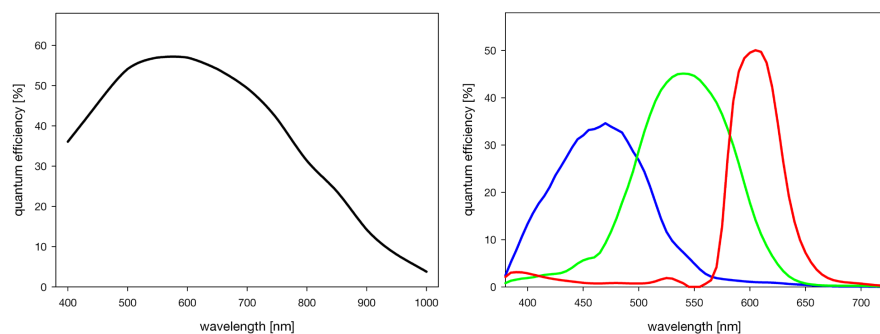

A2 Mechanical Dimensions

All dimensions given in millimeter.

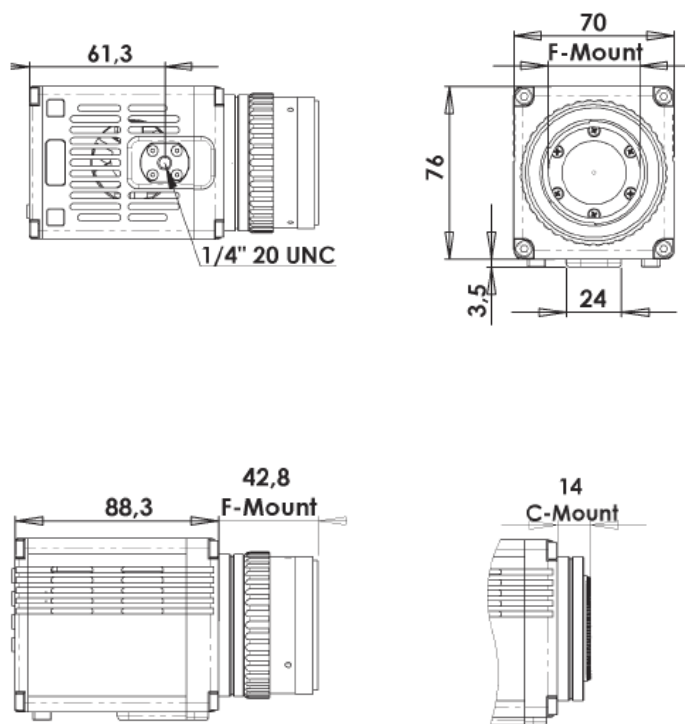

A3 How to change optical input F-mount to C-mount

Step #1: Remove F-mount Adapter

Grasp the F-mount adapter at the blue ring (counter ring) and turn counterclockwise.

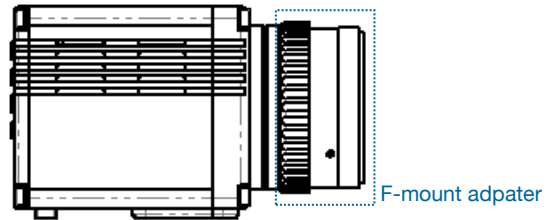

Step #2: Insert C-mount Ring

Carefully screw the ring completely in and tighten the two Allen screws.

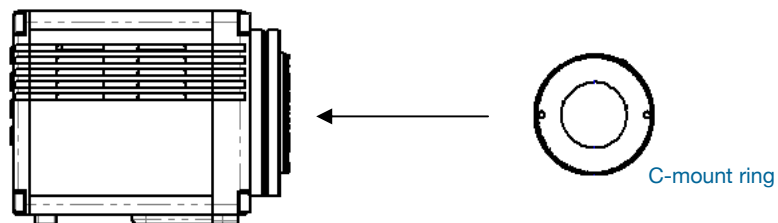

Adjust Back Focal Length

If needed, loosen Allen screws and adjust C-mount ring until image appears sharp. Then tighten Allen screws again.

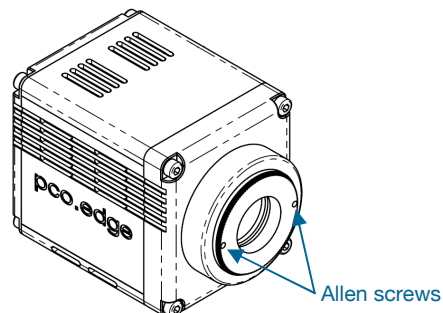

A4 Image File Formats

There are different file formats available for saving camera images with Camware.

b16

The "b16" 16 bit format is similar to the bmp format. However, 16 bit pixel values are used instead of 8 bit pixel values. The 16 bit pixel values represent "unsigned integer values", where the camera (12 bit values) sets the higher 4 bits to zero.

The file format consists either of a "Basic Header" (6 Long-parameter) or of an "Extended Header" (32 Long-parameter), the latter of which is optionally for additional information. There might follow a variable comment field (ASCII code). Finally, there is the actual data set that is saved linearly (as in the case of BMP files).

With the exception of the first value, all parameters are "Long Integers" (4 Byte). The first 6 parameters must always exist. The rest of the parameters, as well as the comment field, are optional.

	Parameter	Function
1	"PCO-"	the first 4 byte are the characters "PCO-"
2	file size	file size in byte
3	header length	header size + comment filed in byte
4	image width	image width in pixel
5	image height	image height in pixel
6	extended header	-1 (true), extended header follows
7	color mode	0 = black/with camera, 1 = color camera
8	b/w min	black/white LUT-setting, minimum value
9	b/w max	black/white LUT-setting, maximum value
10	b/w linlog	black/white LUT-setting, 0 = linear, 1 = logarithmic
11	red min	red LUT-setting, minimum value
12	red max	red LUT-setting, maximum value
13	green min	green LUT-setting, minimum value
14	green max	green LUT-setting, maximum value
15	blue min	blue LUT-setting, minimum value
16	blue max	blue LUT-setting, maximum value
17	color linlog	color LUT-setting, 0 = linear, 1 = logarithmic
18 ... 266	internal use	
Comment file in ASCII characters with variable length of 0..XX. The length of the comment filed must be documented in the "header length" field.		
16 bit pixel data		
	line 1, pixel 1	value of the first pixel
	line 1, pixel 2	value of the second pixel

We recommend that all images should be saved first in the b16 or TIFF format. The advantage is to have the b16 or tiff images available all the time. You will always have the maximum 12 bit information. Please note that not all image analysis programs can accommodate 16 bit data. The 8 bit format saves only the information displayed on the monitor screen. The 12 bit information will be lost and cannot be displayed later.

TIFF

Tag Image File Format, version 6.0 and lower. There is a 16bit monochrome and color image format.

BMP

Windows Bitmap Format, b/w or color 8 bit format-images, which have been saved in BMP format can be loaded later only as 8 bit images, i.e. part of the original information (10bit, 12bit or 14bit) is lost.

FTS

Flexible Image Transport System, Version 3.1. There is a 16 bit image format. The NASA/Science Office of Standards and Technology (NOST) has defined this format. Some programs use the FIT extension for this format.

ASCII

16 bit format, some mathematical programs prefer ASCII data.

JPG

JPEG (named after the Joint Photographic Experts Group who created the standard) is a commonly used method of lossy compression for photographic images. The degree of compression can be adjusted, allowing a selectable tradeoff between storage size and image quality.

JP2

JPEG 2000 is a wavelet-based image compression standard and coding system. It was created by the Joint Photographic Experts Group committee in the year 2000 with the intention of superseding their original discrete cosine transform-based JPEG standard (created 1992).

AVI

Audio Video Interleave is a multimedia container format introduced by Microsoft in November 1992 as part of its Video for Windows technology.

MPG

MPEG-1, similar to JPEG, is a standard for lossy compression of video and audio developed by the Moving Picture Experts Group (MPEG).

WMV

Windows Media Video (WMV) is a compressed video compression format for several proprietary codecs developed by Microsoft. The original video format, known as WMV, was originally designed for Internet streaming applications, as a competitor to RealVideo.

A5 Service and Maintenance

Service

The camera is designed to operate with no need of special adjustments or periodic inspections.



Maintenance

Unplug the camera from any power supply before cleaning it.



Use a soft, dry cloth for cleaning the camera.
Do not use liquid cleaners or sprays.

The lens is best cleaned with pressurized air or with liquid cleaners such as pure alcohol or with special optical cleaners that are available at high quality photo stores.

Never use aggressive cleaning liquids such as gasoline, acetone, spirits or nitro cleanser.

Every time the input window is cleaned, there is the possibility of surface damage. Do not clean the input window unless it is absolutely necessary. Be careful and avoid scratches and damage to the input window surface.

Use a cotton swab dipped in pure alcohol or optical cleaning liquid and wipe only on the glass surface. Do not get any cleaning liquid on the metallic parts such as the lens thread, because tiny detached particles may scratch the surface.

Always store the camera with the protective cap or with a lens mounted to avoid dust and dirt on the input window!



Camera Disposal

The camera includes electronic devices, which can contain materials harmful to the environment. If the camera is to be discarded, please dispose of it in an environmentally responsible manner and use recycling facilities, where available.

A6 Customer Service and Trouble Shooting

If you have a question, which is not adequately addressed in this manual, please contact PCO or your local dealer.

To speed your request, we need the following information:

- Short description of the problem
- Description of your application
- Camera settings
- Type and version of camera software being used
- Camera serial number
- Operating system (PC)
- Processor type (PC)
- Memory
- Graphic card
- Graphic card setup

Please use the email options under the Help menu (see 7.8),



or go to our website: <http://www.pco.de/support-request/>

Before sending the camera for repair, first contact your local dealer or PCO respectively.



When shipping the camera for repair, be certain to carefully pack the camera with proper shipping materials. If possible use the original packaging. Use the protection cap to protect the camera on the lens thread.

A7 Firmware Update

Please contact our support team for further information and assistance!



A8 Digital Camera Tools CD-ROM

You will find all necessary software and drivers on the accompanying CD.

For the latest versions please check our website:

Home Company Products Support Library Contact
English | Deutsch



Overview

by Category

- sCMOS Cameras
- Sensitive Cameras
- Intensified Cameras
- High Speed Cameras
- Specialized Cameras
- OEM Cameras
- Camera Software
- Accessories

by Application

- Life Science
- Physical Science
- Machine Vision
- Automotive

sCMOS Cameras

pco.edge

Product Details Technical Data More Info

The new pco.edge is a breakthrough in scientific imaging cameras, due to its distinctive ability to simultaneously deliver extremely low noise, fast frame rates, wide dynamic range, high quantum efficiency, high resolution and large field of view - all in one image.

» Datasheet | » Software | » Drivers | » Manuals | » Where to get the product

Areas of Application

- live cell microscopy
- single molecule detection
- super resolution microscopy
- TIRF microscopy / waveguides
- spinning disk confocal microscopy
- genome sequencing (2nd and 3rd gen)
- FRET
- FRAP
- lucky astronomy / imaging
- adaptive optics
- solar astronomy
- fluorescence spectroscopy
- bio- & chemi-luminescence
- high content screening
- photovoltaic inspection
- x-ray tomography
- ophthalmology
- flow cytometry
- biochip reading
- machine vision
- TV / broadcasting
- spectral (hyperspectral) imaging
- laser induced breakdown spectroscopy (LIBS)
- particle image velocimetry

« Back to overview







PCO AG © 2008 | Imprint | Terms & Conditions | Disclaimer | Privacy Policy

A9 Global Shutter - Rolling Shutter

Global Shutter

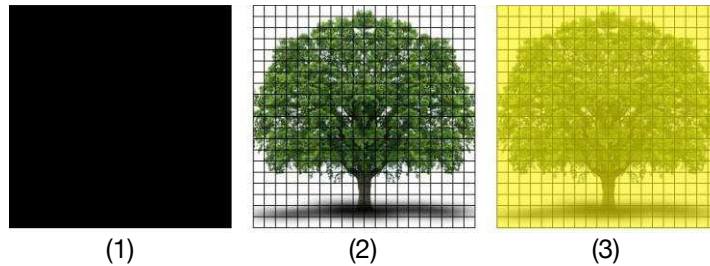
In **global shutter** mode all pixels of the sensor are reset at the same time (1), exposure starts for all pixels at the same time (2), exposure stops and read-out starts at the same time (3).



Rolling Shutter

In **rolling shutter** mode the pixel reset and exposure start is carried out line by line. The pco.edge image sensor consists of two discrete halves, which are exposed and read out simultaneously, i.e. from the outside to the centre.

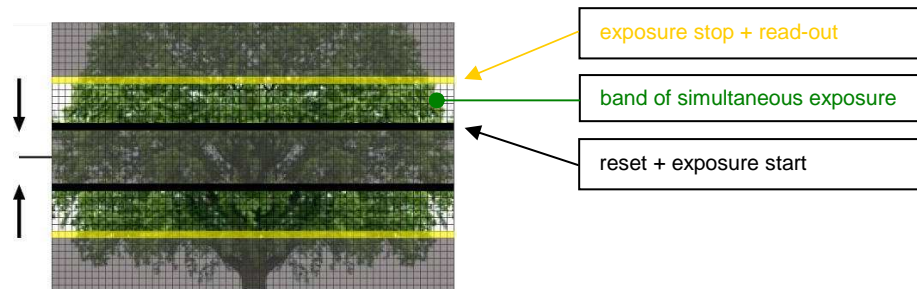

Exposure time < Sensor frame readout time

In case the required exposure is shorter than the frame readout time, the image is composed of two moving exposure bands from the outside to the centre of the sensor.

Exposure time = Sensor frame readout time

In case the required exposure is equal to the frame readout time, the image sensor is totally exposed to light only for a few microseconds.

Exposure time > Sensor frame readout time

In case the required exposure is longer than the frame readout time, the image sensor is completely exposed to light for some time. In case of a triggered flash illumination, this would be the best moment to illuminate the image sensor.

maximize the moment

PCO AG was founded in 1987. The company headquarters in Kelheim employs more than 50 specialists in the development and production of optimized, fast, sensitive camera systems for scientific applications. PCO's range of products includes digital camera systems featuring high dynamics, extremely high sensitivity, high resolution, high speed, and extremely low noise, which are sold in industrial and scientific markets all over the world.

Cameras for every point of view.

The systems produced by PCO AG are cameras and scientific measuring instruments at the same time. Our high-tech systems are mostly the result of manual labor: over 50 highly specialized employees handle development and production at the Kelheim site. We deliver roughly 4.000 cameras a year to customers all over the world. As in every cutting edge technology, dialogue with the user is the main focus of PCO's approach. Worldwide representatives, in cooperation with the in-house marketing division and technical support team, ensure that PCO camera systems are developed in step with the individual requirements of our customers.

pco.
imaging

